

# SPECIALIST RANGE FOR TRUCK & BUS

A COMPREHENSIVE PRODUCT OVERVIEW

2019



FleetRunner™





# CATALOGUE SEARCH

FIND PARTS FOR YOUR VEHICLE



SEARCH MAKE, MODEL OR PART NUMBER...



## 3 WAYS TO SEARCH ABOVE



### Catalogue Search

Easily search the Gates automotive catalogue to find quality aftermarket replacement parts

**QUICKLY FIND ALL YOUR TRUCK & BUS PARTS ON [WWW.GATESAUTOCAT.COM](http://WWW.GATESAUTOCAT.COM)**



**ACCESSORY BELT DRIVE SYSTEM..... 6-9**

FleetRunner™ Micro-V® Belts..... 6  
FleetRunner™ Micro-V® Stretch Fit® Belts ..... 6  
FleetRunner™ Tensioners ..... 7  
FleetRunner™ Micro-V® Kits..... 8  
FleetRunner™ V-belts & PowerBand® Belts..... 9

**COOLING SYSTEM.....10-14**

COOLANT HOSE ..... 10  
    FleetRunner™ Standard EPDM/Neoprene Hose..... 10  
    FleetRunner™ Standard EPDM/Aramid Hose ..... 11  
    FleetRunner™ Silicone Hose (OAT resistant)..... 12  
    FleetRunner™ Curved Hose ..... 12  
  
HEATER HOSE ..... 13  
    FleetRunner™ Straight EPDM Heater Hose..... 13  
    FleetRunner™ Straight Silicone Heater Hose..... 13

HOSE CONNECTORS (ID 6-25 mm) ..... 13

THERMOSTATS ..... 14

**FUEL SYSTEM ..... 15**

FUEL HOSE..... 15  
    FleetRunner™ Fuel Line Hose..... 15  
    FleetRunner™ Barricade® Fuel Line Hose ..... 15  
    FleetRunner™ Flexible Fuel Fill Hose..... 15

HOSE CONNECTORS (ID 2-12 mm) ..... 15

**TURBOCHARGER HOSE..... 16**

FleetRunner™ Straight Silicone Turbocharger Hose ..... 16  
FleetRunner™ Silicone Turbocharger Hose Kits..... 16

**MISCELLANEOUS HOSE .....17-18**

Flexible Air Vent Hose ..... 17  
Flexible Heavy Duty Air Vent Hose..... 17  
Flexible Air Duct Hose ..... 17  
Defroster Hose ..... 18  
Windscreen Washer and Vacuum Hose ..... 18



# INTRODUCING FLEETRANNER™, GATES' DEDICATED HEAVY-DUTY AFTERMARKET PARTS PROGRAMME

---

Being an Original Equipment supplier with a global footprint and coverage, Gates applies the same quality standards in the manufacturing of all FleetRunner™ parts.

This makes them premium-quality solutions that keep your engines running more efficiently for longer periods of time, saving money on maintenance and maximising road time.

***Available from stock across Europe,  
the Middle East and Africa.***

---







| **FleetRunner**<sup>™</sup>







## FLEETRANNER™ MICRO-V® BELTS (8542)

Gates knows what counts in OEM quality and makes it count in aftermarket quality as well: FleetRunner™ belts stand for reliability of the highest level. Gates' advanced technology in materials and design allows FleetRunner™ belts to provide superior flexibility, stability, load-carrying capacity and unsurpassed belt life. What is more, FleetRunner™ belts are able to operate and accept misalignment in the accessory belt drive system better than other aftermarket belts which makes them the perfect problem-solver.

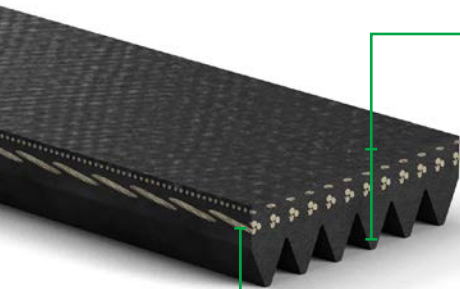

### ■ Aramid fibre-reinforced EPDM overcord (cover) and undercord (ribs)

- Hard-wearing
- Highly resistant to cracks
- Very flexible
- Reliable, even in the high heat conditions of modern truck diesel engines
- Increased flex life thanks to low belt profile

### ■ Advanced polyester or aramid tensile cord materials

- High strength
- Low stretch
- Optimum load-carrying capacity at even the highest tensions

## FLEETRANNER™ MICRO-V® STRETCH FIT® BELTS (8542)

Commercial vehicle manufacturers use specially engineered elastic belts for heavy duty engines that are not equipped with an accessory drive belt tensioning device. These factory-fitted elastic belts may only be replaced by the application-specific elastic replacement belt. Gates offers the ideal response with the FleetRunner™ Micro-V® Stretch Fit® range.

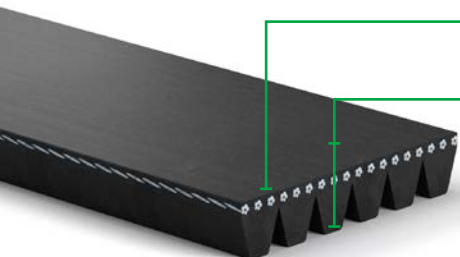

### ■ Strong and stretchable cord design – ensures maximum tension-holding capability throughout the entire life span of the belt

### ■ EPDM construction – makes the belt extremely resistant to oil, leaks, wear and pilling

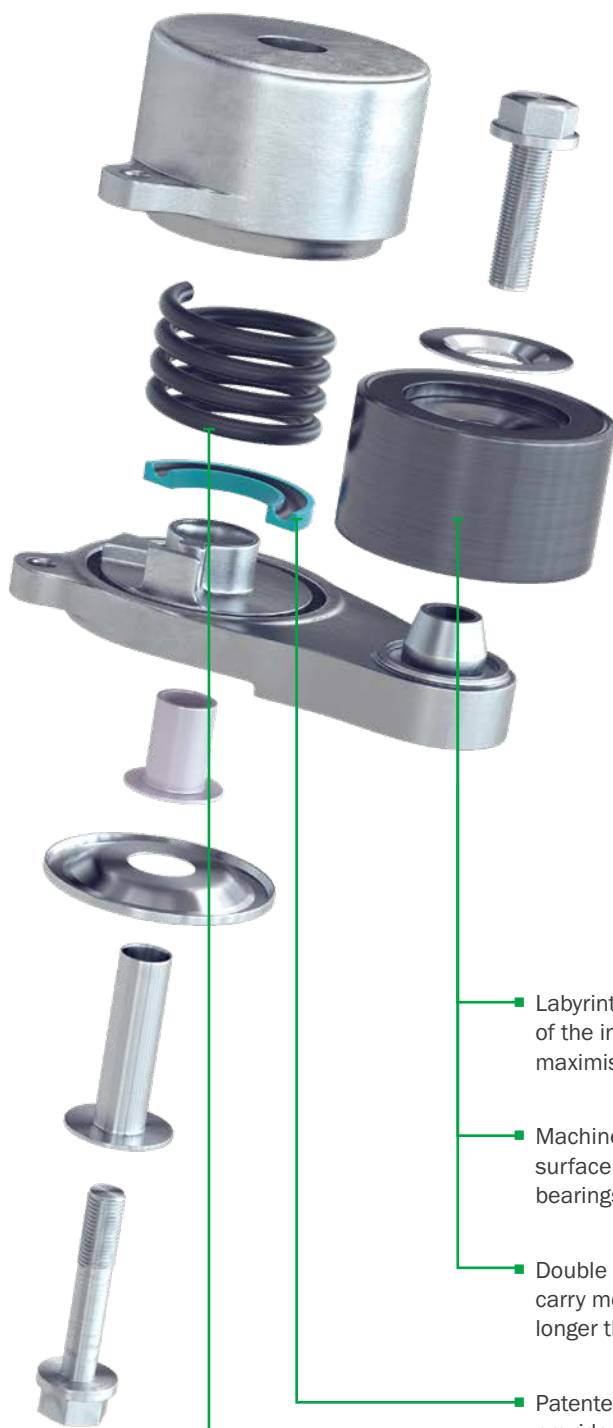
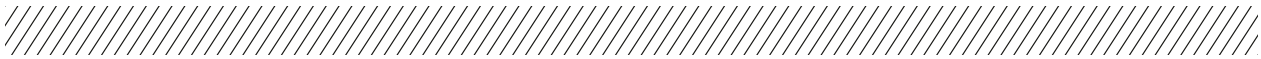

## FLEETRANNER™ TENSIONERS (7808) (7803)

Gates is one of the largest OE manufacturers of automatic tensioners, including around 170 tensioner references specifically for Heavy Commercial Vehicles. With their many patented features FleetRunner™ tensioners are engineered to exceed demanding OEM requirements. In laboratory tests and under extreme peak-to-peak vibration and contamination tests, they lasted up to three times longer than competitive aftermarket tensioners.

- Labyrinth seal – prevents contamination of the internal parts which maximises tensioner service life
- Machined steel pulley – reduces surface wear while shielding the internal bearings from outside contaminants
- Double row bearings – twin rows of bearings carry more load and last up to three times longer than two individual bearings
- Patented damping mechanism – provides maximum stability, reducing vibration and extending the life of the belt, the tensioner and the other accessory belt drive components
- Round spring wire – more flex fatigue resistant than a flat spring design

## FLEETRANNER™ MICRO-V® KITS (8572)

It is important to use a system approach when diagnosing and servicing the accessory belt drive. The system's components are designed to work and wear together. When a high mileage belt is replaced, the tensioner has likely met its life cycle as well. Maintain optimum system performance by inspecting and replacing all system components together. With FleetRunner™ Micro-V® kits from Gates, you get all the quality parts for a complete system overhaul in one handy box.

- All-in-one kit with the application-specific FleetRunner™ Micro-V® belt(s), FleetRunner™ tensioner(s) and FleetRunner™ idler(s), tensioner bolts (parts as required)
- Restoring the complete system with perfectly matched OE-quality components prevents costly comebacks
- Ordering only one product saves time and therefore, money
- One warranty covers all parts
- Some kits offer improvements over OE designs, solving problems that have been discovered through thousands of kilometers of heavy duty maintenance histories





## FLEETRANNER™ V-BELTS

FleetRunner™ V-belts are all high-performance belts that are designed to cope with the very harsh operating conditions of modern truck diesel engines. The special heavy-duty construction resists cracking, wear, heat and oil. Our range includes different types of V-belts, to fit all your needs.



### FLEETRANNER™ V-BELT - BANDED (8527) (8569)

- Belts with a special cover that provides maximum protection in severe working conditions.



### FLEETRANNER™ V-BELT - MOULDED NOTCH (8701) (8537)

- Belts with a unique undercord notch pattern that offers increased flexibility for smaller diameter pulleys and reduces the bending stress, thereby reducing the heat generated by rapid flexing which is one of the causes of premature belt failure.



### FLEETRANNER™ POWERBAND® - BANDED (8582)

- Belts consisting of two or more banded V-belts joined together by a permanent reinforced rubber tie band. Specially suited for vibration and shock sensitive drives where single belts turn over or jump off the pulleys.



### FLEETRANNER™ POWERBAND® - MOULDED NOTCH (8541)

- Belts consisting of two or more moulded notch V-belts joined together by a permanent reinforced rubber tie band. Specially suited for vibration and shock sensitive drives where single belts turn over or jump off the pulleys.

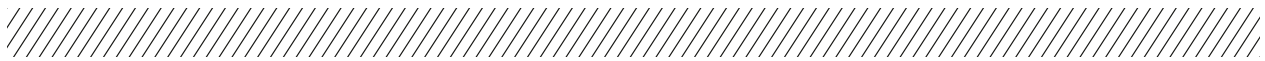

## COOLANT HOSE

As a pioneering company in high-technology automotive products, Gates has over 30 years of experience in hose manufacturing allowing full control of the production process and quality of the product. We design, manufacture and supply a great variety of coolant hoses that fit and perform exactly like the original.

The extensiveness of our range ensures you will find coolant hoses for all truck and bus makes and models.

### STANDARD EPDM/NEOPRENE HOSE



#### **FLEETRANNER™ GREEN STRIPE® STRAIGHT HOSE (4168)**

EPDM, POLYESTER REINFORCED

- Engineered to resist electrochemical degradation, the leading cause of hose failure
- EPDM tube, synthetic fabric reinforcement plies, EPDM cover with wrapped appearance
- Temperature range from -40 °C to +135 °C
- Meets requirements of SAE 20R1, class D, type EC, standard wall



#### **FLEETRANNER™ GREEN STRIPE® WIRE-INSERTED HOSE (4685)**

EPDM, METAL REINFORCED

- EPDM tube, synthetic fabric reinforcement with vulcanised metal wire, EPDM cover with wrapped appearance
- Bends easily to make curved connections, providing the ability to replace many curved hose sizes and shapes
- Temperature range from -40 °C to +125 °C for coolant, +100 °C for air
- Meets requirements of SAE 20R5, class C



#### **FLEETRANNER™ GREEN STRIPE® VULCO-FLEX® HOSE (4284)**

EPDM/NEOPRENE, METAL REINFORCED

- Engineered to resist electrochemical degradation, the leading cause of hose failure
- EPDM tube, polyester fabric reinforcement with built-in spiral wire, EPDM cover
- Bends easily to make curved connections, providing the ability to replace many curved hose sizes and shapes
- Temperature range from -40 °C to +125 °C
- Meets requirements of SAE 20R5, class D2, type EC





## STANDARD EPDM/ARAMID HOSE



### FLEETRANNER™ FLEXCORD PLUS HOSE (4272)

EPDM, ARAMID REINFORCED

- Engineered to resist electrochemical degradation, the leading cause of hose failure
- EPDM tube, aramid knit reinforcement, EPDM cover
- Temperature range from -40 °C to +135 °C
- Meets requirements of DIN 73411, class B1 and SAE 20R4, class D2



### FLEETRANNER™ 90° HOSE (4278)

EPDM, ARAMID REINFORCED

- Engineered to resist electrochemical degradation, the leading cause of hose failure
- EPDM tube, aramid fibre reinforcement, EPDM cover
- Temperature range from -40 °C to +135 °C
- Meets requirements of SAE 20R4, class D2, type EC and DIN 73411, class A

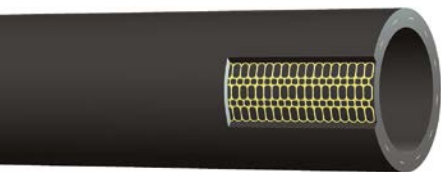

### FLEETRANNER™ 45° HOSE (4278)

EPDM, ARAMID REINFORCED

- Engineered to resist electrochemical degradation, the leading cause of hose failure
- EPDM tube, aramid fibre reinforcement, EPDM cover
- Temperature range from -40 °C to +135 °C
- Meets requirements of SAE 20R4, class D2, type EC and DIN 73411, class A





## SILICONE HOSE (OAT RESISTANT)

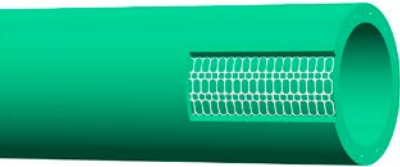

### FLEETRANNER™ STRAIGHT SILICONE HOSE (4171)

- Functions perfectly as radiator, heater or other coolant transfer hose in poorly ventilated conditions
- Green silicone tube, synthetic fibre reinforcement, green silicone cover
- Temperature range from -40 °C to +176 °C
- Meets requirements of SAE 20R1, class A, standard wall

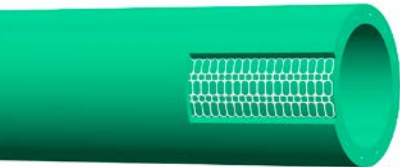

### FLEETRANNER™ 90° SILICONE HOSE (4281)

- Green silicone tube, polyester fibre reinforcement, green silicone cover
- Temperature range from -50 °C to +180 °C
- Exceeds requirements of SAE 20R1, class A except burst



### FLEETRANNER™ 45° SILICONE HOSE (4281)

- Green silicone tube, polyester fibre reinforcement, green silicone cover
- Temperature range from -50 °C to +180 °C
- Exceeds requirements of SAE 20R1, class A except burst



## CURVED HOSE

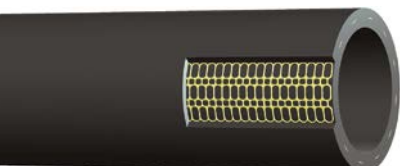

### FLEETRANNER™ CURVED HOSE (4275)

- EPDM tube, aramid or rayon knit reinforcement, EPDM cover
- Temperature range from -40 °C to +125 °C, occasionally to +135 °C
- Meets requirements of SAE 20R4, class D2, type EC and SAE 20R3, class D1, type EC (under  $\varnothing$  25mm) and DIN 73411, class A (over  $\varnothing$  25mm)







## HEATER HOSE



### FLEETRANNER™ STRAIGHT EPDM HEATER HOSE (4230)

EPDM, SYNTHETIC REINFORCED

- EPDM tube, synthetic fibre reinforcement, EPDM cover
- Temperature range from -40 °C to +125 °C
- Meets requirements of SAE 20R3, class D2 except hardness (70-85 Shore A durometer)



### FLEETRANNER™ STRAIGHT SILICONE HEATER HOSE (3231)

SILICONE, SYNTHETIC REINFORCED

- High temperature silicone for extreme heat exposure
- Silicone tube, reinforced with tough, high-temperature resistant polyester tensile cords, silicone cover
- Temperature range from -54 °C to +177 °C
- Meets requirements of SAE 20R3 HT, class A

## HOSE CONNECTORS (ID 6-25 MM) (7315)

Gates hose connectors are recommended for small diameter heater and radiator hoses to provide a better seal between hoses with either the same or different inside diameters. Using straight, reducer, elbow and “T” connectors, almost any hose configuration can be constructed.

- Made of 100% glass-reinforced nylon
- Resistant to coolant additives, petrol, diesel, oil and LPG
- Anti-rotation device prevents the hose from twisting off the fitting
- Single-barb design ensures a leak-proof seal
- Superior resistance to extreme temperatures from -65 °C to +250 °C
- Maximum working pressure up to 2 MPa (20 kg/cm<sup>2</sup>)



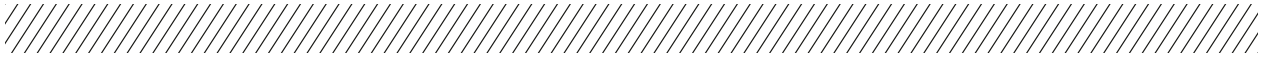

## THERMOSTATS (7412)

Gates offers competitively priced OE-design thermostats to meet the needs of today's truck and bus engines. They provide an exact fit to avoid leaks and function precisely to keep engine temperatures strictly within original equipment specifications. Their quality construction ensures a long, trouble-free life.

Our range includes numerous types of thermostats in order to provide the same design as specified by truck and bus manufacturers.

- Supplied with the matching gasket or seal according to the corresponding OE offer
- Precise engine operating temperature control
- Optimum engine warm-up & performance
- Good fuel economy & low emissions



## FUEL HOSE

Whether you need a fuel hose or the connectors that go with them, you want parts that are reliable and last longer. That's exactly what Gates offers with its fuel hose programme: we design and manufacture every Gates hose and connector to the most stringent standards in the industry, ensuring uncompromising quality and 100% reliability.



### FLEETRANNER™ FUEL LINE HOSE (3225)

TEXTILE REINFORCED

Small-diameter multi-purpose hose designed for fuel circuits.

- Nitrile tube, synthetic fibre reinforcement, nitrile/PVC cover
- Working pressure up to 1 MPa (10 kg/cm<sup>2</sup>)
- Temperature range from -40 °C to +125 °C
- Not for in-tank (submersible) applications, sour gas, LPG and biodiesel
- Meets requirements of SAE 30R7 and DIN 73379, except tolerances



### FLEETRANNER™ BARRICADE® FUEL LINE HOSE (4219BG)

BARRIER: THERMOPLASTIC LINER

Low-permeation fuel line hose.

- Multiple fuel compatibility: Petrol, E10, E15, E85, diesel, biodiesel (B0 to B100: SME, PME, RME)
- Low permeation <15g/m<sup>2</sup>/day: Meets EPA and CARB requirements
- Working pressure up to 0.34 MPa
- Temperature range from -40 °C to +125 °C and +100 °C for biodiesel B-10 to B-100



### FLEETRANNER™ FLEXIBLE FUEL FILL HOSE (4663)

HELICAL WIRE REINFORCED

Flexible hose for a perfect connection between filler neck and fuel tank.

- Nitrile tube, synthetic fabric reinforcement plies with a vulcanised metal wire, neoprene coated fabric cover
- Temperature range from -40 °C to +100 °C
- Meets requirements of SAE 30R5

## HOSE CONNECTORS (ID 2-12 MM) (7315)

Gates connectors are recommended for small-diameter fuel line hoses to provide a better seal between hoses with either the same or different inside diameters. Using straight, elbow, reducer, "T" and "Y" shapes, almost any hose configuration can be constructed.

- Unique single-barb design ensures a leak-proof seal
- Resistant to coolant additives, petrol, diesel, oil and LPG
- Glass-reinforced nylon resists extreme temperatures from -65 °C to +250 °C
- Working pressure up to 2 MPa (20 kg/cm<sup>2</sup>)



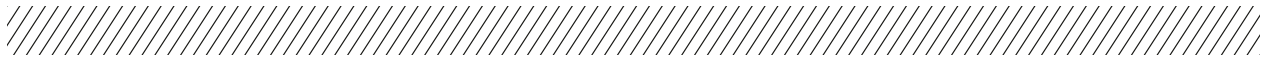

When turbocharger hoses require replacement, insist on top-quality hoses from Gates. With our own manufacturing facility, we produce turbocharger hoses for heavy commercial vehicles that are made to the exact same quality standards as the original hose.

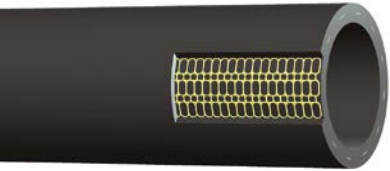

## **FLEETRANNER™ STRAIGHT SILICONE TURBOCHARGER HOSE (4177)**

Universal turbocharger hose that can easily be cut off to the required length.

- Fluorocarbon (FKM) tube, high tensile polyester knit reinforcement, silicone cover
- Temperature range from -50 °C to +170 °C with peaks up to +200 °C
- Meets requirements of SAEJ200

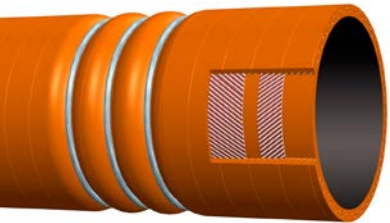

## **FLEETRANNER™ SILICONE TURBOCHARGER HOSE KITS (4177)**

Application-based kits including the specific turbocharger hose and premium T-bolt clamps.

- Fluorocarbon (FKM) tube, high tensile woven meta-aramid knit, silicone cover
- Temperature range from -50 °C to +230 °C with peaks up to +270 °C
- Meets requirements of SAEJ200





## **FLEXIBLE AIR VENT HOSE (4663)**

Extremely flexible hose for air cleaner-to-engine connections, defroster ducts and air or heater ducting.

- Diameter of 16 to 92 mm
- Neoprene tube, fabric ply reinforcement with vulcanised metal wire, neoprene cover
- Temperature range from -34 °C to +121 °C



## **FLEXIBLE HEAVY DUTY AIR VENT HOSE (4663)**

High-strength, flexible hose for air cleaner-to-engine connections.

- Diameter of 102 to 140 mm
- Neoprene tube, extra thick fabric layer reinforcement and double steel wire, neoprene cover
- Temperature range from -34 °C to +121 °C



## **FLEXIBLE AIR DUCT HOSE (7743)**

Connects hot air sources with air cleaners for more efficient control of emissions. Helps eliminate carburetor icing and improves engine warm-up.

- Corrugated aluminium hose
- Extremely flexible, yet retaining its shape after being formed
- Temperature range from -40 °C to +250 °C





## DEFROSTER HOSE (7768)

A hose that shapes and cuts easily. Recommended for low pressure or suction applications such as defrosters, air ducts and air intakes.

- Closely woven, rubber-impregnated fabric tube with strong helical wire reinforcement
- Temperature range from -40 °C to +107 °C



## WINDSCREEN WASHER AND VACUUM HOSE (4040)

The ideal hose to replace the PVC tubing used for windscreen or headlight washers in cars, to connect vacuum-operated accessories and to discharge radiator overflow or rainwater.

- EPDM tube and cover
- Temperature range from -40 °C to +125 °C
- Meets requirements of SAE J1037, SAE 942, SAE J200 M4CA710 A25 B35 C32 EA14 F19





**DRIVEN BY POSSIBILITY™**

**FOR MORE INFORMATION, VISIT [GATES.COM](https://www.gates.com)**

The manufacturers reserve the right to amend details where necessary.  
E2/70619 - © Gates Corporation - Printed in Belgium - 05/19.